



GTO

A fully automatic inline tray-sealing system designed to increase line speeds and cut labour costs.

This machine fills a gap in the market for a high quality compact fully automatic tray sealer. It will also run with existing tooling from rotary machines with minor modifications thus minimising costs. Accepts randomly spaced trays from any conveyor and delivers straight on to check weight / metal detector.

Optional 'free flow' gas flush available for extended shelf life.

materials This machine has the ability to heat-seal and perimeter trim (inboard trimming option available) film lids on to CPET, APET, Polypropylene, PVC, Styrene, Board, Smooth Walled Foil, Pre-cut Board, Paper, Plastic, Foil Lids and many other types of containers.

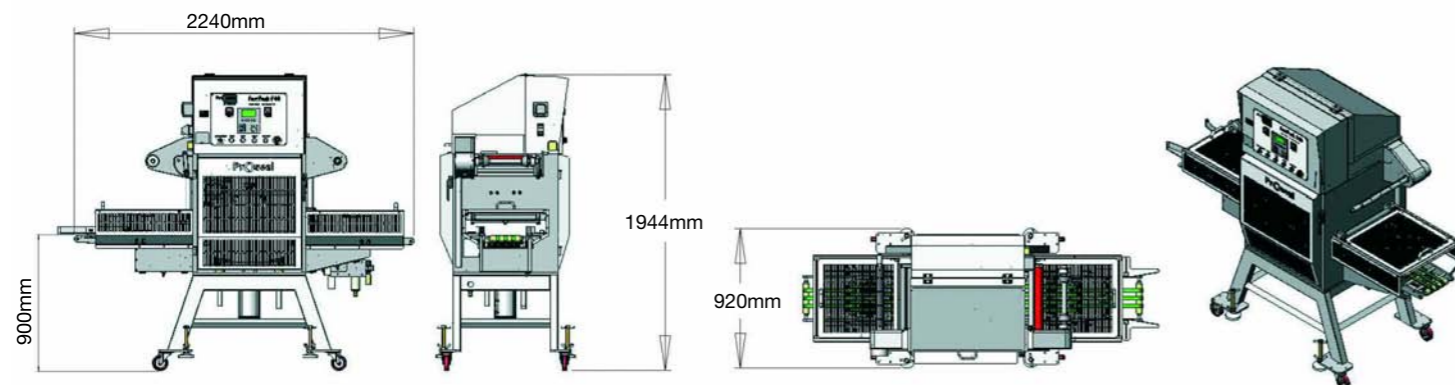

Standard features and benefits

- Fully portable
- Maintenance friendly robust construction
- Low maintenance polymer bearings
- Food Industry approved hygienic construction and wash down protection
- Category 3 safety guards
- Three minute tool changeover
- Accurate temperature and seal pressure control
- Simple and accurate film-feed system with easy film route
- Panel mounted film-tension adjustment
- High accuracy tool alignment system provides a constantly accurate sealing and film-cutting relationship with the tray flange profile
- Simple double-sided operation
- Recipe handling of machine settings
- 'Setting Free' automatic tray collation infeed
- Self diagnostic system

- User friendly, menu-driven control panel with-step-by-step prompts, error and status displays, and useful batch pack counter
- Pot crush detection

Options available

- Free flow gas flush MAP (Modified atmosphere packaging)
- High oxygen gas flush
- Pre-printed film
- Film snap detection
- Film coding and printing
- Foil crimping
- Peripheral equipment integration
- Active conveyors
- Auto tool clamp and connection
- Back-to-back machine configurations

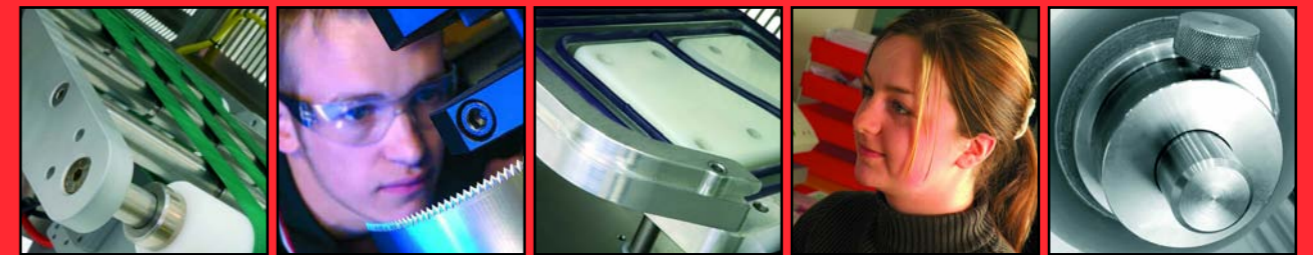

Service and maintenance All our automatic machines benefit from a comprehensive twelve months parts and labour warranty and a 24 hour service back-up facility, to assure our valued customers of our confidence in the build quality and our commitment to you. Naturally, all machine components are held in stock at Proseal. Service Cover 24 hours, 7 days a week.

Sealing capacity

| Number of trays | Length | Width | Depth | Diameter |
|-----------------|--------|-------|-------|----------|
| One | 426mm | 270mm | 105mm | 270mm |
| Two | 270mm | 200mm | 105mm | 200mm |
| Three | 270mm | 127mm | 105mm | 125mm |

Specifications

| | |
|-------------------|---|
| Height | 1944mm |
| Length | 2240mm |
| Width | 920mm |
| Weight | 580 Kg |
| Electrical supply | 240v 2Kw single phase (fused at 13 Amps) |
| Pneumatic supply | 25CFM (707L/Min) at 80PSI (6 bar) |
| Production speed | 15 cycles per minute (45 packs per minute for 3 impression tools) |

designers and manufacturers of tray sealing machinery
www.proseal.com email info@proseal.com