



## GTR

A semi-automatic two station rotary table heat-sealing machine. It is fully portable with automatic film-feed and capable of sealing up to 30 packs per minute.

This machine is the workhorse of the ready meal industry. Ultra reliable and easy to operate, it is being used around the world and has become the benchmark for portable heat-sealing equipment.

Optional 'free flow' gas flush available for extended shelf life.

**materials** This machine has the ability to heat-seal and perimeter trim (inboard trimming option available) film lids on to CPET, APET, Polypropylene, PVC, Styrene, Board, Smooth Walled Foil, Pre-cut Board, Paper, Plastic, Foil Lids and many other types of containers.

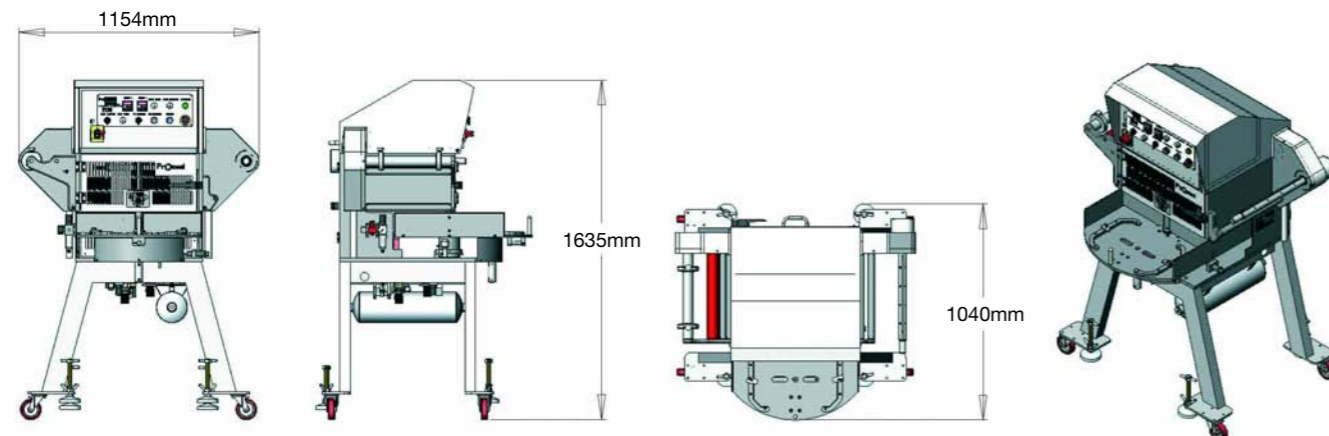

### Standard features and benefits

- Fully portable
- Maintenance friendly robust construction
- Low maintenance polymer bearings
- Food Industry approved hygienic construction and wash down protection
- Category 3 safety guards
- Three minute tool changeover
- Accurate temperature and seal pressure control
- Simple and accurate film-feed system with easy film route
- 'Lock and release' rotary table
- High accuracy tool alignment system incorporating revolutionary table damping system
- Tool alignment system incorporating our revolutionary 'Lock and release' table damping system
- High accuracy tool alignment system provides a constantly accurate sealing and film-cutting relationship with the tray flange profile

### Options available

- Free flow gas flush MAP (Modified atmosphere packaging)
- High oxygen gas flush
- Pre-printed film
- Film coding and printing
- Foil crimping
- Deep pot machine configuration
- Pastry blocking
- Pharmaceutical Blister Packaging Machines
- Sandwich Pack Sealing for Card, Recyclable and Non Recyclable Plastic

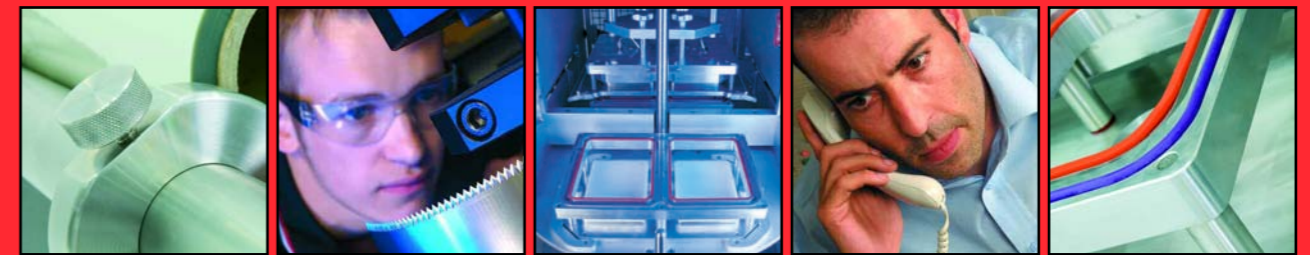

**Service and maintenance** All our automatic machines benefit from a comprehensive twelve months parts and labour warranty and a 24 hour service back-up facility, to assure our valued customers of our confidence in the build quality and our commitment to you. Naturally, all machine components are held in stock at Proseal. Service Cover 24 hours, 7 days a week.

### Sealing capacity

Number of trays	Length	Width	Depth	Diameter
One	280mm	230mm	227.5mm	300mm
Two	230mm	150mm	227.5mm	200mm
Four	150mm	120mm	227.5mm	130mm

### Specifications

Height	1635mm
Length	1040mm
Width	1154mm
Weight	220 Kg
Electrical supply	240v 2Kw single phase (fused at 13 Amps)
Pneumatic supply	8CFM (230L/Min) at 80PSI (6 bar)
Production speed	15 cycles per minute max (up to 30p.p.m with 2-lmp tools)

designers and manufacturers of tray sealing machinery  
[www.proseal.com](http://www.proseal.com) email [info@proseal.com](mailto:info@proseal.com)